

Wymiary gabarytowe pomp PZ3-III-2

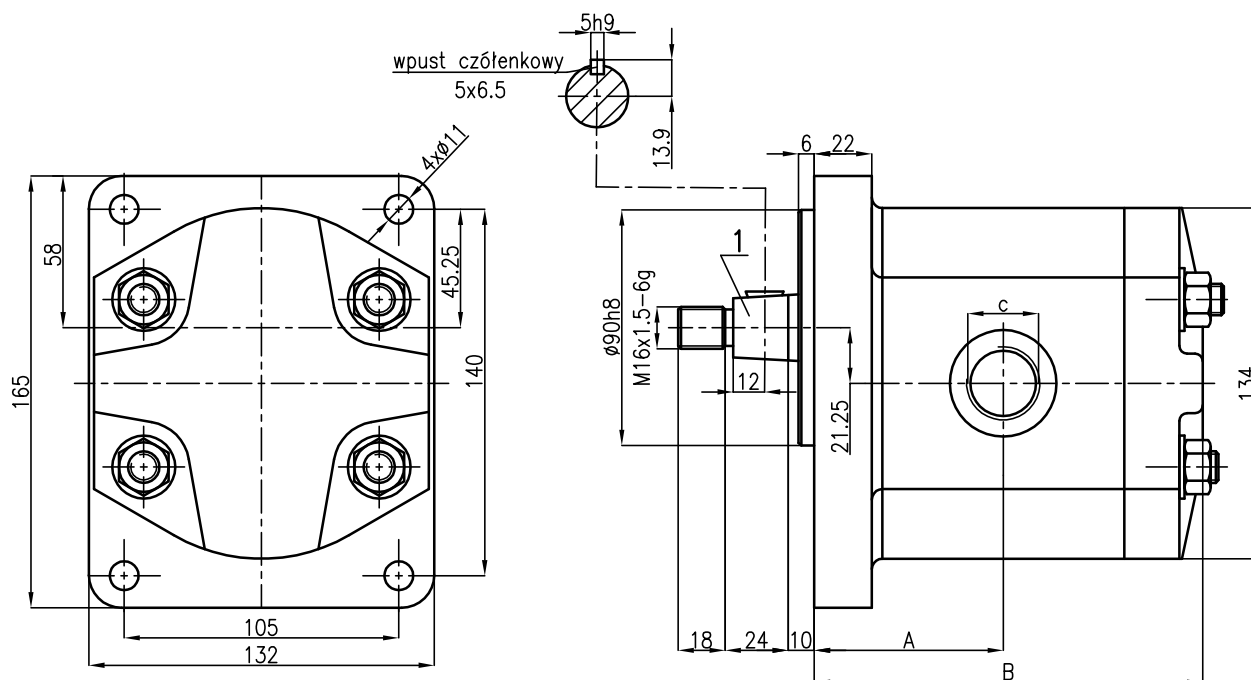

- 1 - czop stożkowy 1:10
- 2 - czop wielowypustowy 25x1.25x10d wg PN-69/M-85010
- 4 - czop walcowy

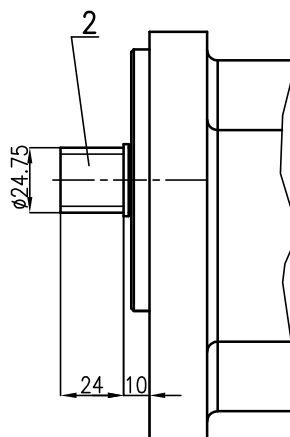
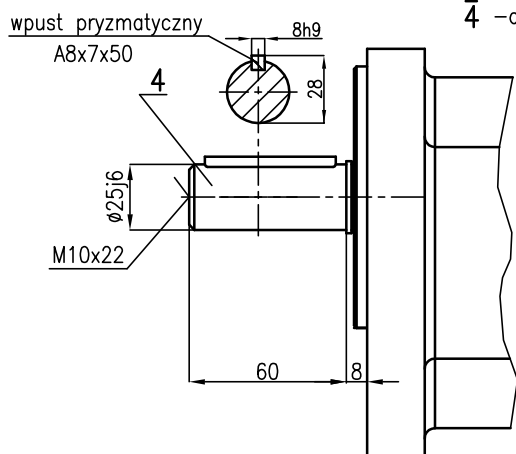

Wielkość pompy cm ³ /obr	Oznaczenie pompy	Wymiary [mm]		Gniazda gwintowe
		A	B	wejście i wyjście c
12.5	PZ3-12.5/20-x-122 PZ3-12.5/20-x-222	66.2	131	M22x1.5A
16	PZ3-16/20-x-122 PZ3-16/20-x-222	68	135	M27x2A
20	PZ3-20/20-x-122 PZ3-20/20-x-222	70	139	M27x2A
25	PZ3-25/20-x-122 PZ3-25/20-x-222	72.2	143.5	M27x2A
32	PZ3-32/16-x-122 PZ3-32/16-x-222 PZ3-32/16-x-422	75.7	150.5	M33x2A
40	PZ3-40/16-x-122 PZ3-40/16-x-222 PZ3-40/16-x-422	80	159	M42x2A
50	PZ3-50/12.5-x-122 PZ3-50/12.5-x-222 PZ3-50/12.5-x-422	85	169	M42x2A
60	PZ3-60/12.5-x-122 PZ3-60/12.5-x-222 PZ3-60/12.5-x-422	89.5	178	M42x2A

x-kierunek obrotów (1-lewy; 2-prawy)